

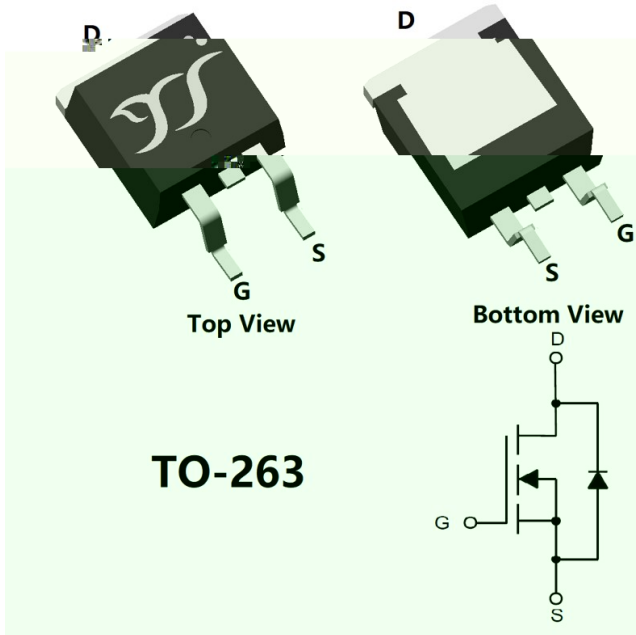

YJB270G10H

N-Channel Enhancement Mode Field Effect Transistor



Product Summary

General Description

Applications

Absolute Maximum Ratings

Parameter	Symbol	Limit	Unit

Thermal resistance

Parameter	Symbol	Typ	Max	Units

Ordering Information

PREFERRED P/N	PACKING CODE	Marking	MINIMUM PACKAGE(pcs)	INNER BOX QUANTITY(pcs)	OUTER CARTON QUANTITY(pcs)	DELIVERY MODE



YJB270G10H

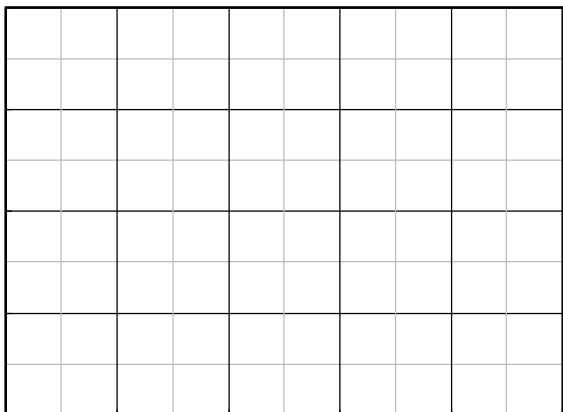
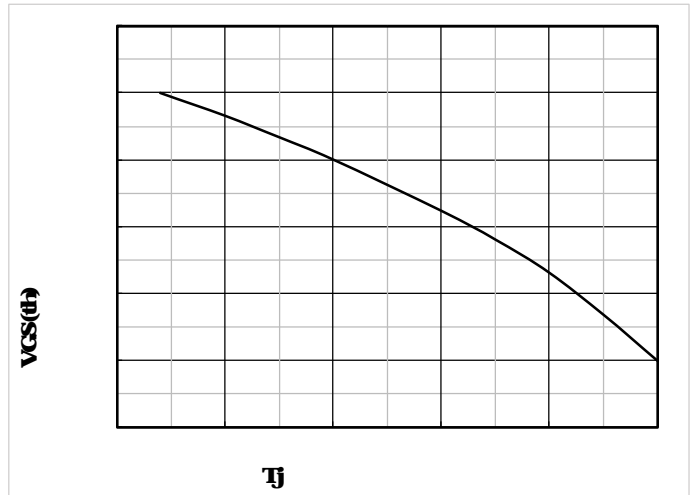
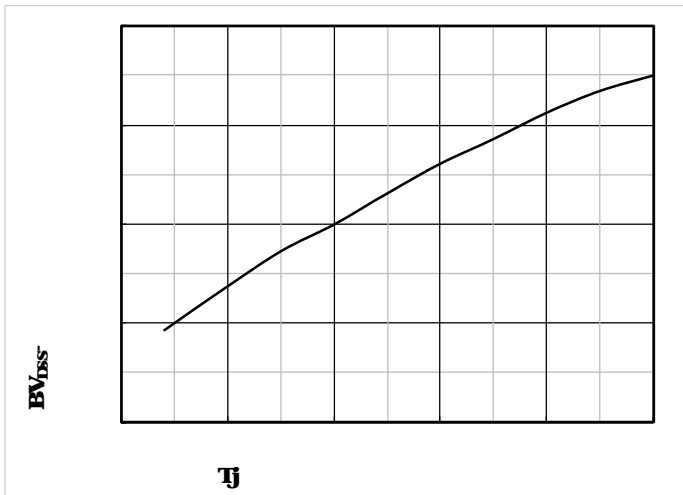
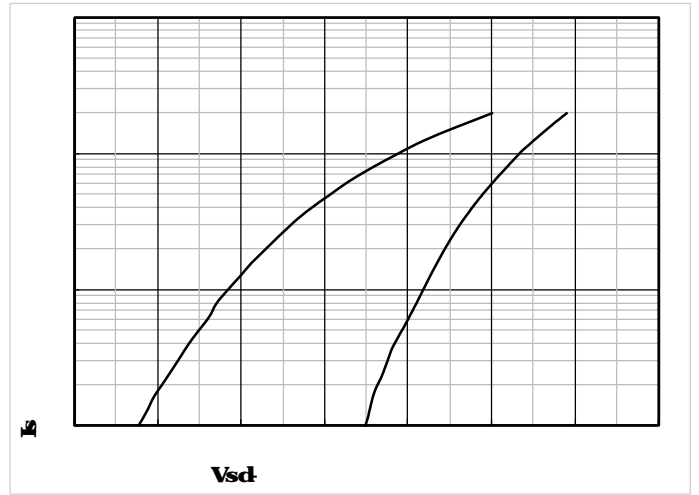
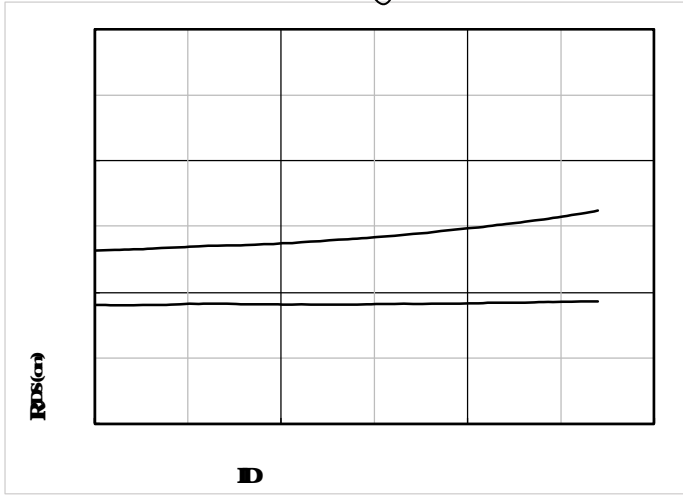



YJB270G10H

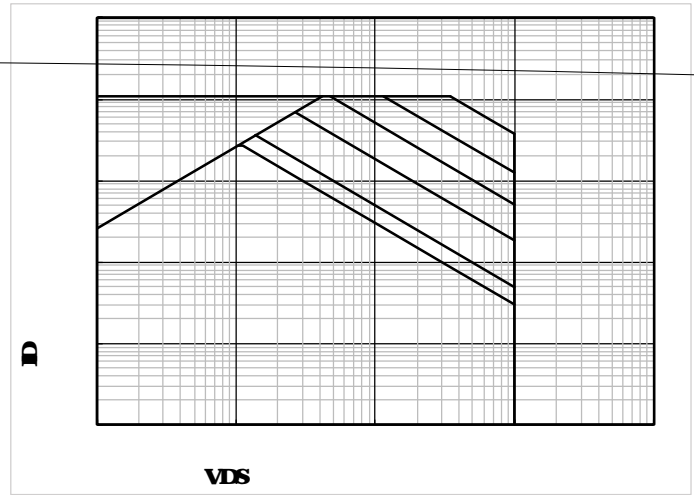
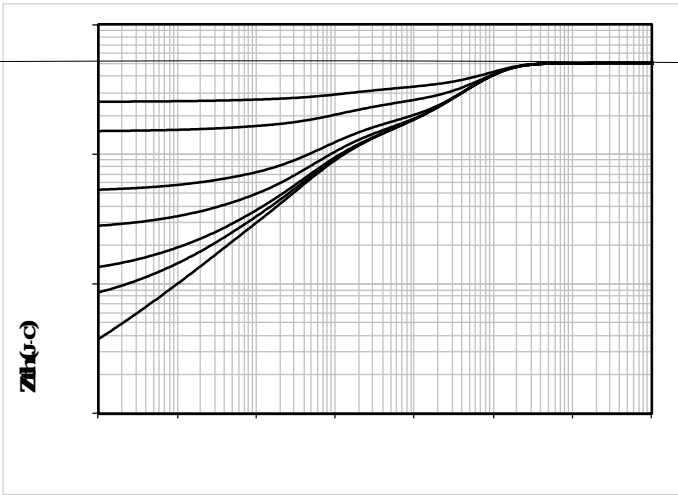



YJB270G10H

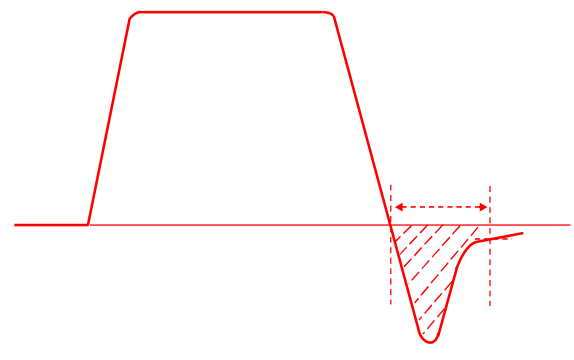
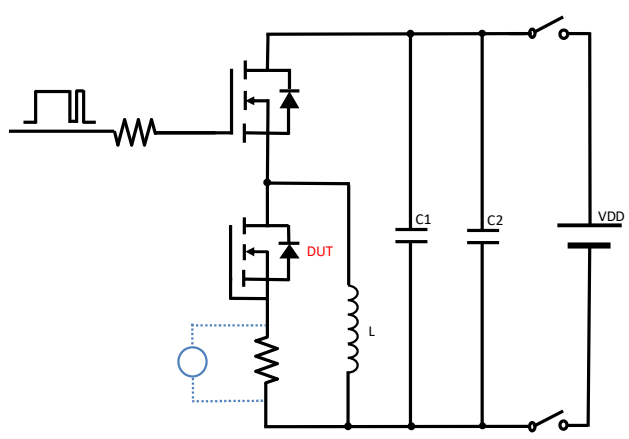
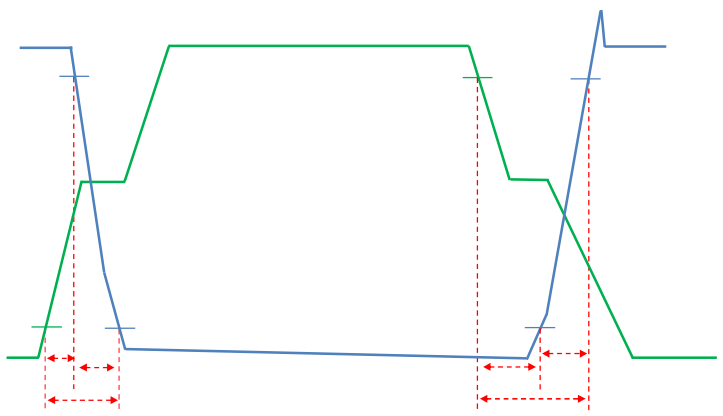
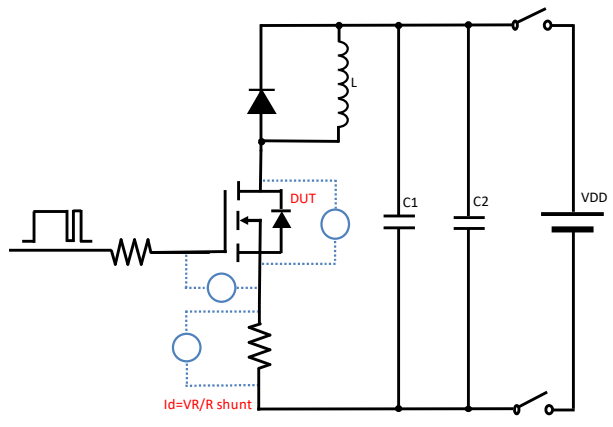
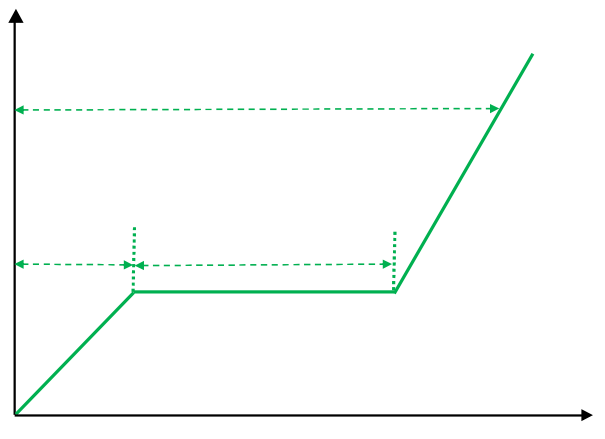
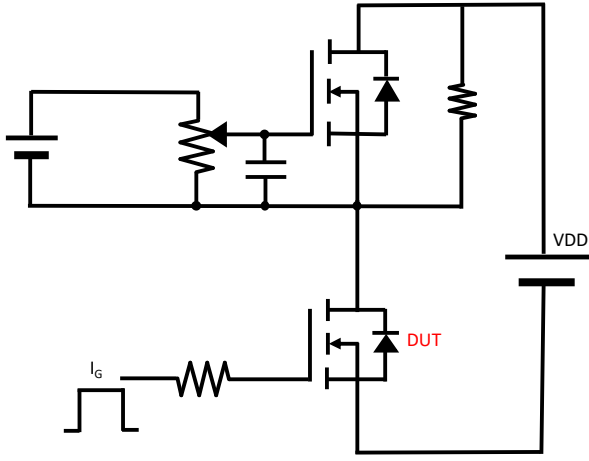



TO 263 B Package information

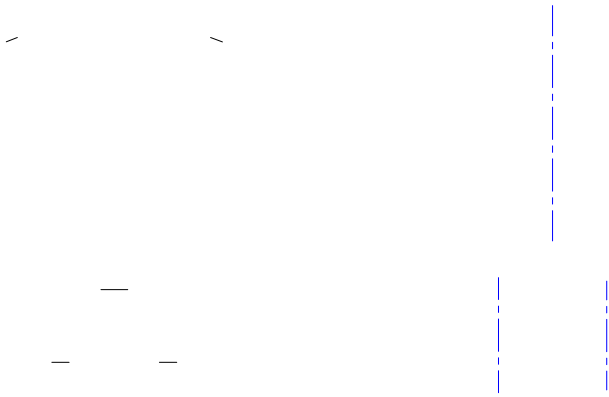
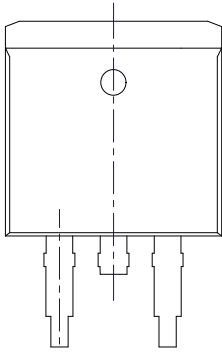



YJB270G10H

Disclaimer
