



YJD110G08A

N-Channel Enhancement Mode Field Effect Transistor

Product Summary

| | |
|-----------------------------------|------|
| V_{DS} | 80V |
| I_D | 110A |
| $R_{DS(ON)}$ (at $V_{GS}=10V$) | 6m |
| $R_{DS(ON)}$ (at $V_{GS}=4.5V$) | 7m |
| 100% EAS Tested | |
| 100% V_{DS} Tested | |

General Description

Split gate trench MOSFET technology
 Excellent package for heat dissipation
 High density cell design for low $R_{DS(ON)}$
 Moisture Sensitivity Level 1
 Epoxy Meets UL 94 V-0 Flammability Rating
 Halogen Free

Applications

Power switching application
 Uninterruptible power supply
 DC-DC convertor

Absolute Maximum Ratings ($T_A=25$ unless otherwise noted)

| Parameter | | Symbol | Limit | Unit |
|--|-------------------|----------------|----------|------------|
| Drain-source Voltage | | V_{DS} | 80 | V |
| Gate-source Voltage | | V_{GS} | ± 20 | V |
| Drain Current | $T_A=25^\circ C$ | I_D | 13 | A |
| | $T_A=100^\circ C$ | | 8 | |
| | $T_C=25^\circ C$ | | 110 | |
| | $T_C=100^\circ C$ | | 69 | |
| Pulsed Drain Current ^A | | I_{DM} | 400 | A |
| Avalanche energy ^B | | EAS | 361 | mJ |
| Total Power Dissipation ^C | $T_A=25^\circ C$ | P_D | 2.5 | W |
| | $T_A=100^\circ C$ | | 1 | |
| | $T_C=25^\circ C$ | | 83 | |
| | $T_C=100^\circ C$ | | 33 | |
| Junction and Storage Temperature Range | | T_J, T_{STG} | -55 +150 | $^\circ C$ |

Thermal resistance

| Parameter | | Symbol | Typ | Max | Units |
|---|--------------|----------|------|-----|--------------|
| Thermal Resistance Junction-to-Ambient ^D | Steady-State | R_{JA} | 40 | 50 | $^\circ C/W$ |
| Thermal Resistance Junction-to-Case | Steady-State | R_{JC} | 1.25 | 1.5 | |

Ordering Information (Example)

| PREFERRED P/N | PACKING CODE | Marking | MINIMUM PACKAGE(pcs) | INNER BOX QUANTITY(pcs) | OUTER CARTON QUANTITY(pcs) | DELIVERY MODE |
|---------------|--------------|------------|----------------------|-------------------------|----------------------------|---------------|
| YJD110G08A | F1/F2 | YJD110G08A | 2500 | / | 25000 | 13" reel |



YJD110G08A

Electrical Characteristics (T_J=25 unless otherwise noted)

| Parameter | Symbol | Conditions | Min | Typ | Max | Units |
|---------------------------------------|---------------------|--|-----|------|------|-------|
| Static Parameter | | | | | | |
| Drain-Source Breakdown Voltage | BV _{DSS} | V _{GS} = 0V, I _D =250μA | 80 | - | - | V |
| Zero Gate Voltage Drain Current | I _{DSS} | V _{DS} =80V, V _{GS} =0V | - | - | 1 | μA |
| | | V _{DS} =80V, V _{GS} =0V, T _J =150°C | - | - | 100 | |
| Gate-Body Leakage Current | I _{GSS} | V _{GS} = ±20V, V _{DS} =0V | - | - | ±100 | nA |
| Gate Threshold Voltage | V _{GS(th)} | V _{DS} = V _{GS} , I _D =250μA | 1.4 | 1.8 | 2.5 | V |
| Static Drain-Source On-Resistance | R _{DS(on)} | V _{GS} =10V, I _D =55A | - | 4.2 | 6 | m |
| | | V _{GS} =10V, I _D =20A | - | 4.2 | 6 | |
| | | V _{GS} =4.5V, I _D =55A | - | 5.5 | 7 | |
| Diode Forward Voltage | V _{SD} | I _S =55A, V _{GS} =0V | - | 0.9 | 1.2 | V |
| Gate resistance | R _G | f=1MHz, Open drain | - | 1.9 | - | |
| Maximum Body-Diode Continuous Current | I _S | | - | - | 110 | A |
| Dynamic Parameters | | | | | | |
| Input Capacitance | C _{iss} | V _{DS} =40V, V _{GS} =0V, f=1MHz | - | 6500 | - | pF |
| Output Capacitance | C _{oss} | | - | 850 | - | |
| Reverse Transfer Capacitance | C _{riss} | | - | 35 | - | |
| Switching Parameters | | | | | | |
| Total Gate Charge | Q _g | V _{GS} =10V, V _{DS} =40V, I _D =55A | - | 95 | - | nC |
| Gate-Source Charge | Q _{gs} | | - | 18 | - | |
| Gate-Drain Charge | Q _{gd} | | - | 16 | - | |
| Reverse Recovery Charge | Q _{rr} | I _F =55A, di/dt=400A/us | - | 83 | - | nC |
| Reverse Recovery Time | t _{rr} | | - | 33 | - | ns |
| Turn-on Delay Time | t _{d(on)} | V _{GS} =10V, V _{DD} =40V, I _D =55A R _{GEN} =2.2 | - | 17 | - | ns |
| Turn-on Rise Time | t _r | | - | 90 | - | |
| Turn-off Delay Time | t _{d(off)} | | - | 47 | - | |
| Turn-off fall Time | t _f | | - | 10.5 | - | |

A. Repetitive rating; pulse width limited by max. junction temperature.

B. T_J=25°C, V_{DD}=50V, V_G=10V, R_G=25 , L=0.5mH, I_{AS}=38A.

C. P_d is based on max. junction temperature, using junction-case thermal resistance.

D. The value of R_{JA} is measured with the device mounted on the minimum recommend pad size, in the still air environment with T_A =25°C. The maximum allowed junction temperature of 150°C. The value in any given application depends on the user's specific board design.



YJD110G08A

Typical Electrical and Thermal Characteristics Diagrams

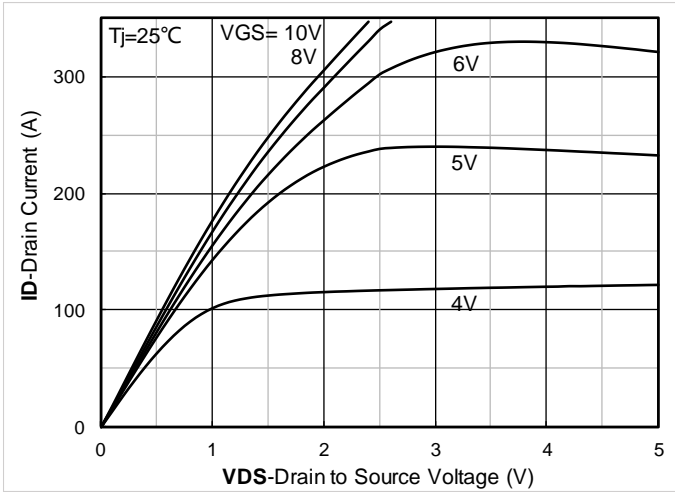

Figure 1. Output Characteristics

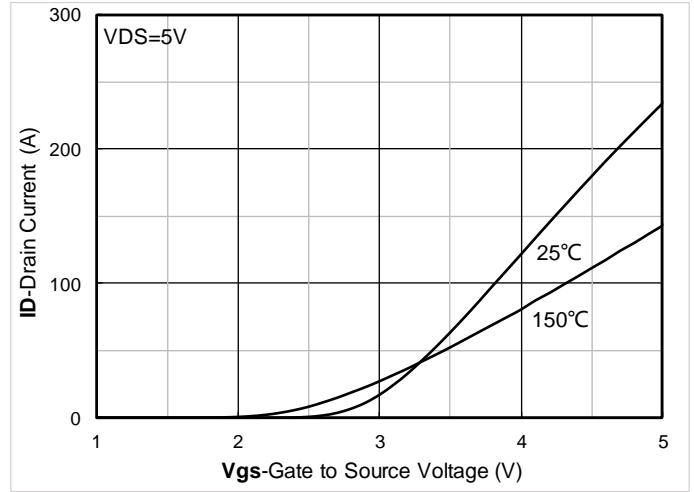

Figure 2. Transfer Characteristics

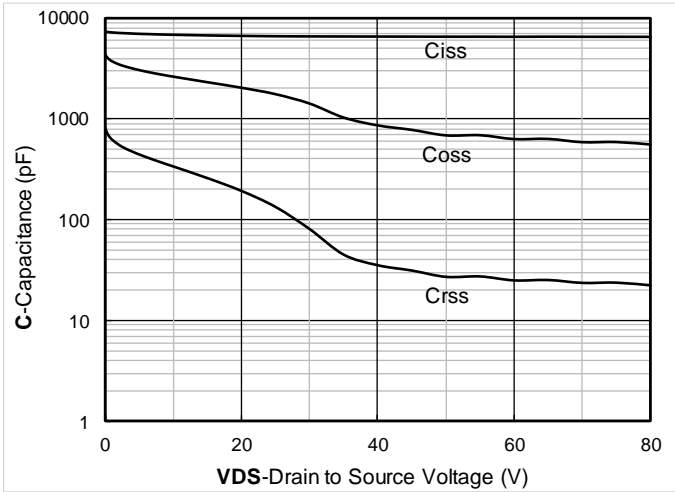

Figure 3. Capacitance Characteristics

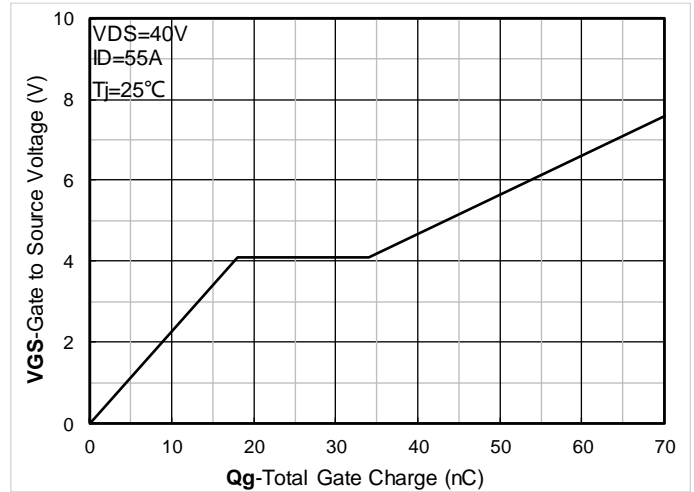

Figure 4. Gate Charge

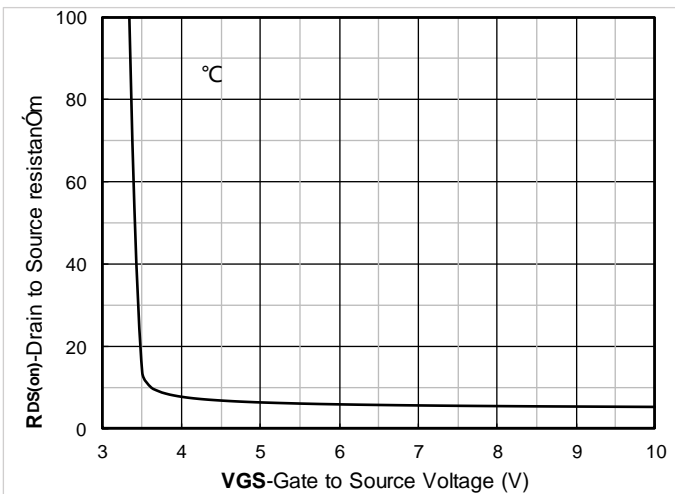

Figure 5. On-Resistance vs Gate to Source Voltage

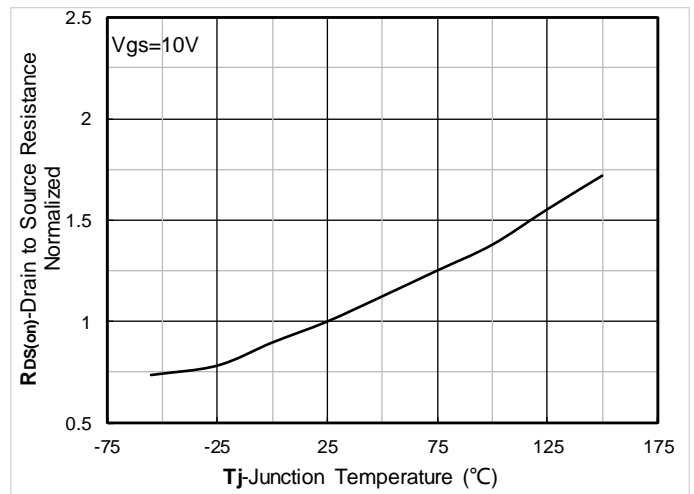

Figure 6. Normalized On-Resistance



YJD110G08A

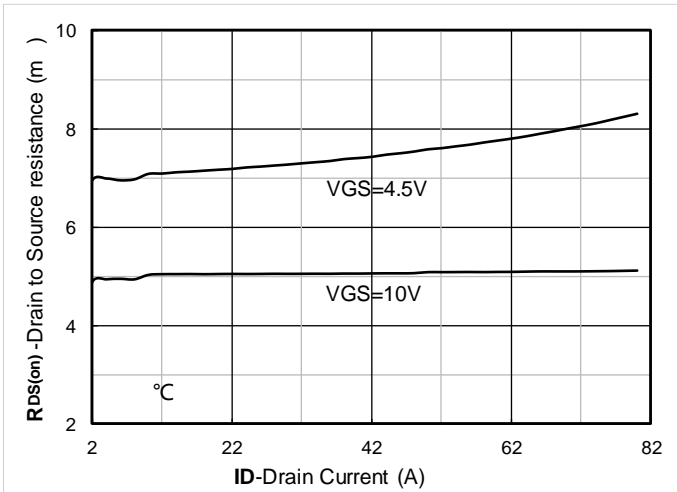

Figure 7. RDS(on) VS Drain Current

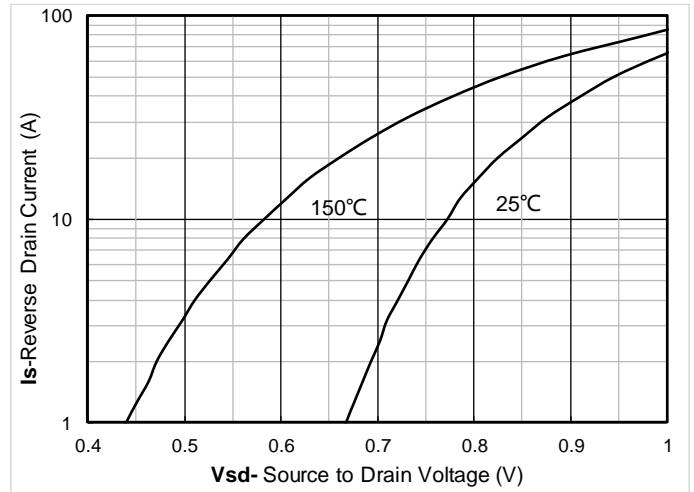

Figure 8. Forward characteristics of reverse diode

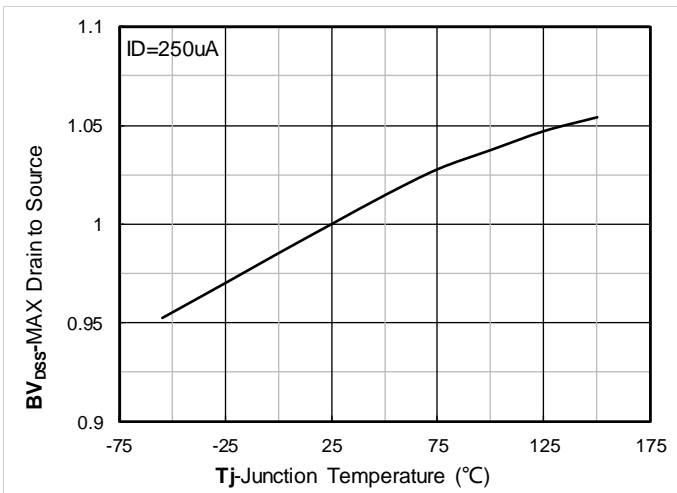

Figure 9. Normalized breakdown voltage

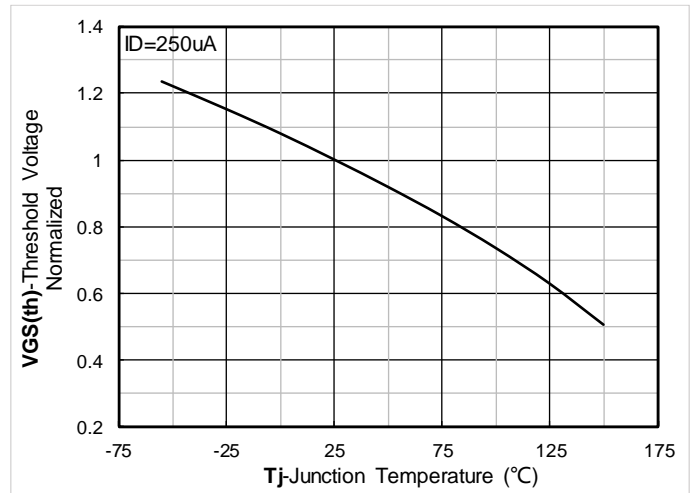

Figure 10. Normalized Threshold voltage

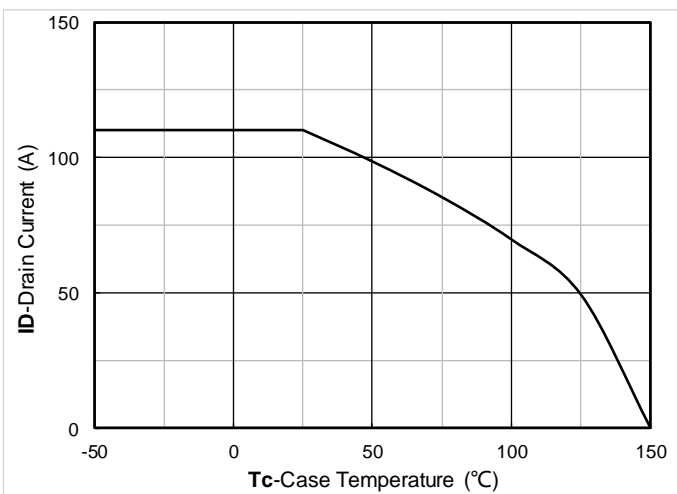

Figure 11. Current dissipation

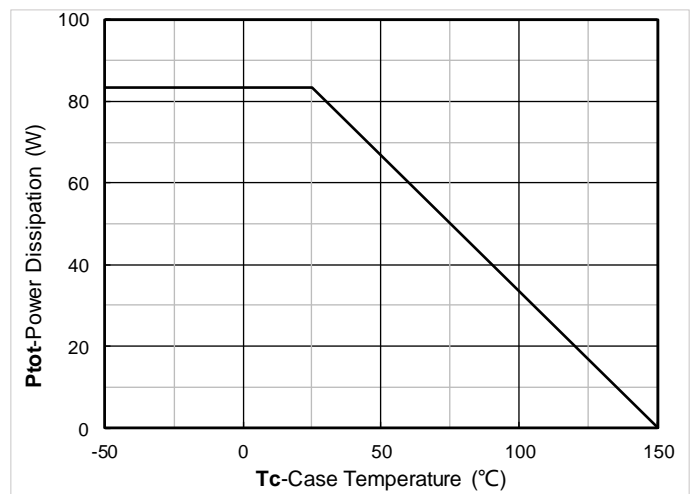

Figure 12. Power dissipation

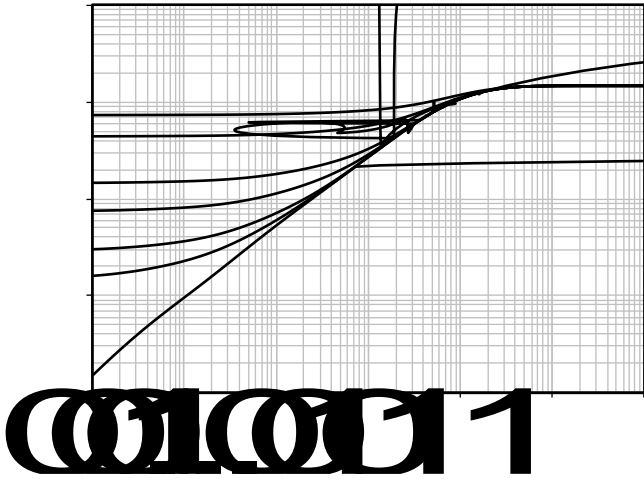

Figure 13. Maximum Transient Thermal Impedance

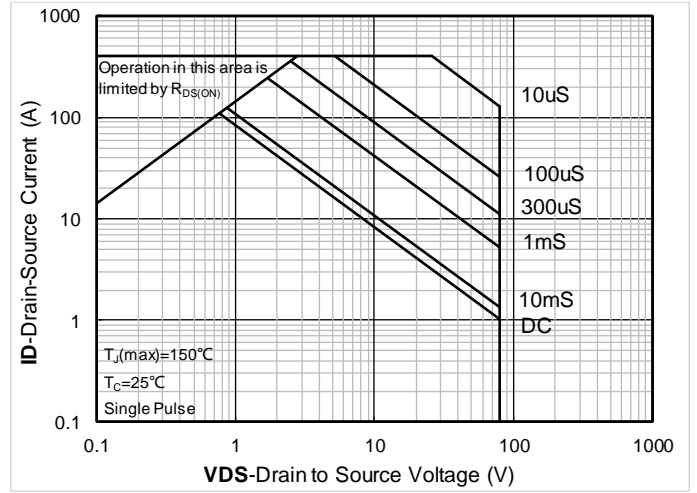

Figure 14. Safe Operation Area

Test Circuits & Waveforms

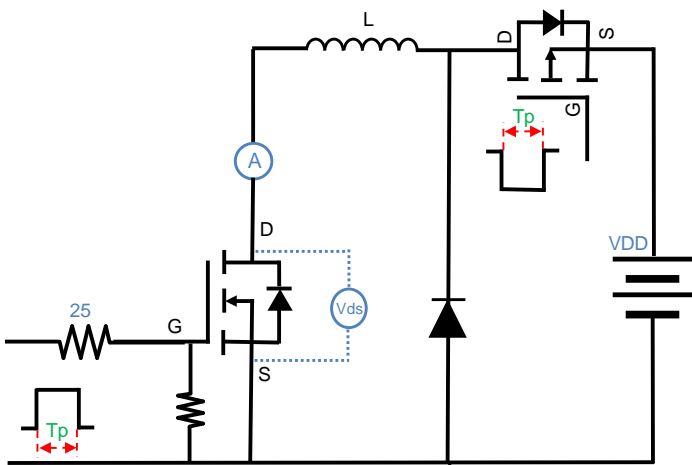

Figure A. Unclamped Inductive Switching (UIS) Test Circuit & Waveform



YJD110G08A

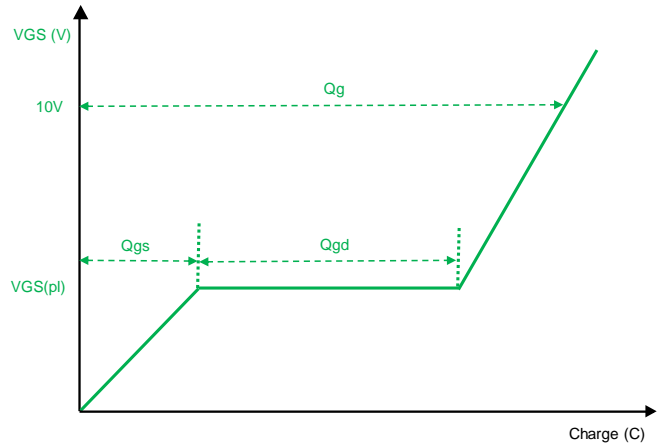
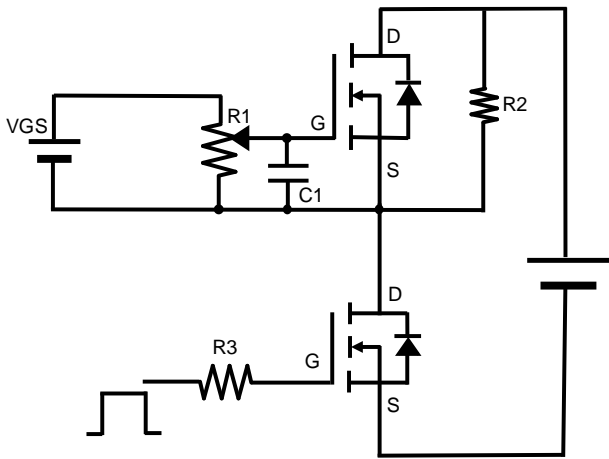

Figure B. Gate Charge Test Circuit & Waveform

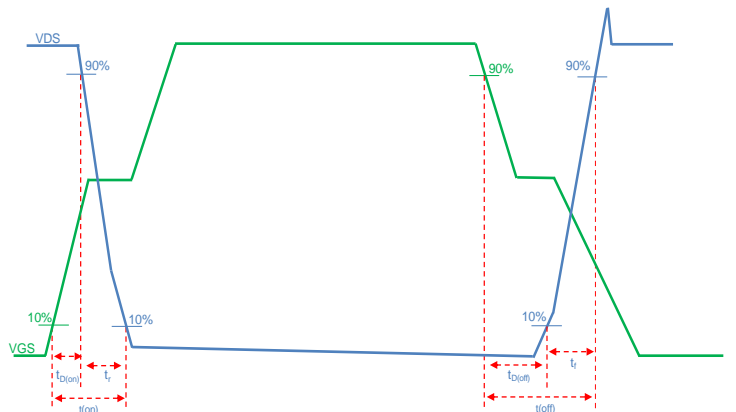
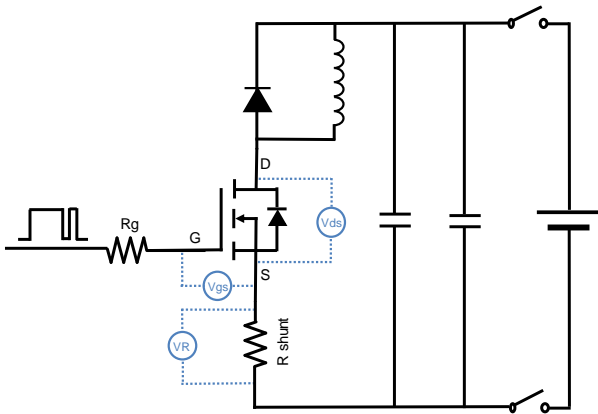

Figure C. Resistive Switching Test Circuit & Waveform

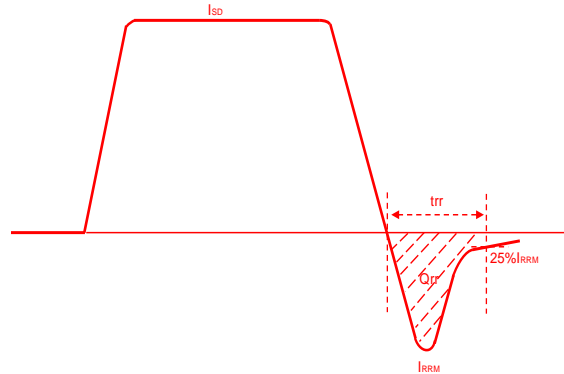
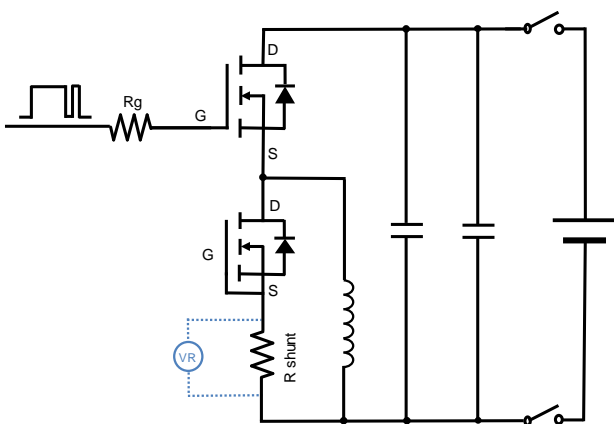

Figure D. Diode Recovery Test Circuit & Waveform



YJD110G08A

Disclaimer

The information presented in this document is for reference only. Yangzhou Yangjie Electronic Technology Co., Ltd. reserves the right to make changes without notice for the specification of the products displayed herein to improve reliability, function or design or otherwise.

The product listed herein is designed to be used with ordinary electronic equipment or devices, and not designed to be used with equipment or devices which require high level of reliability and the malfunction of which would directly endanger human life (such as medical instruments, transportation equipment, aerospace machinery, nuclear-reactor controllers, fuel controllers and other safety devices), Yangjie or anyone on its behalf, assumes no responsibility or liability for any damages resulting from such improper use of sale.

This publication supersedes & replaces all information previously supplied. For additional information, please visit our website <http://www.21yangjie.com> , or consult your nearest Yangjie's sales office for further assistance.